

User Manual

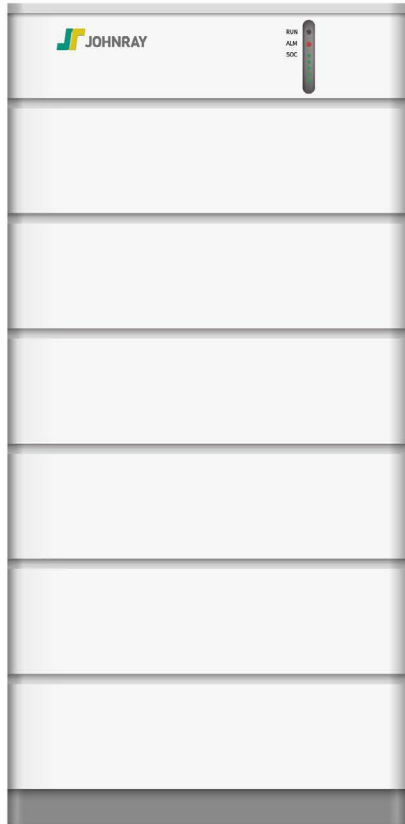

About the manual

This manual describes some important information about the products and shows how to install Johnray ESS battery pack. Read this manual carefully before you attempt to install or use the products, please follow the instructions throughout the installation process. If you are uncertain about any of the requirements, instructions, or safety procedures described in this manual, please contact Johnray service team immediately for advice. A reminder that any damage caused by error in operation deviated from this manual will be not under warranty claim.

NOTE:

This manual is valid only for the Johnray JRH25 high voltage stackable series battery pack (Hereinafter referred to as battery pack).

Abbreviated Terms

PDU	Power distribution unit
SOC	State of charge

Contents

1. Safety

- 1.1 Symbols on Battery label
- 1.2 Important safety instruction
- 1.3 Personal Protective Equipment
- 1.4 Contact information

2. Product Introduction

- 2.1 Battery pack overview
- 2.2 Technical data
 - 2.2.1 Dimensions and weight
 - 2.2.2 Performance
 - 2.2.3 Cable requirement
 - 2.2.4 Environment requirement
- 2.3 Maintenance

3 Installation

- 3.1 Preparation
 - 3.1.1 Installation tools
 - 3.1.2 Location survey
 - 3.1.3 Safety gear
- 3.2 Start Installation
 - 3.2.1 Package item
 - 3.2.2 Installation clearance
 - 3.2.3 Stack
 - 3.2.4 Cable connection

4. Commissioning

- 4.1 Status indicator
- 4.2 Power on battery pack
- 4.3 Shut down battery pack

5. Troubleshooting





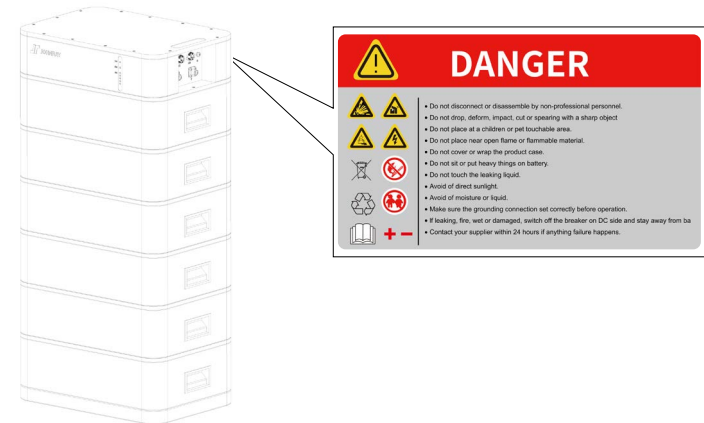

1

Safety

1.1 Symbols on battery pack label

There are some electrical symbols on battery related to electrical safety. Please make sure you have full understanding on them before installation.



-  The voltage of this battery pack is strong enough to cause electric shock.
-  Make sure that the battery polarity is connected correctly.
-  Read the user manual before installing or operating the battery pack.
-  Keep the battery pack away from children.
-  Keep the battery pack away from ignition sources.
-  The battery pack should not be disposed of with household waste at the end of its working life.
-  The battery pack should be recycled.

1.2 Important safety instruction

For safety reasons, please carefully read the manual safety precautions, and observe all the safety instructions in this document before performing installation. Johnray company is not liable for any loss caused due to violation of the instructions in this manual.

In this document we use the following symbols to highlight important information: These warnings and cautions must be followed when using battery pack.

WARNING

Indicates a hazardous situation which, if not avoided, could result in injury or death.

> A battery can present a risk of electrical shock, fire, or even explosion from exposed in vented air due to its active chemical properties, which can bring high dangers. When lithium metal is exposed to air, it will explode due to a violent oxidation reaction with oxygen. Observe proper precautions:

Do not crush, puncture the battery.

Do not dispose of the battery in a fire.

Do not expose the battery pack to direct sunlight.

Do not allow the battery pack connector to touch conductive objects such as wires.

Do not attempt to open, disassemble, tamper with, or modify the battery pack without prior written approval from the JOHNRAY company.

Keep the battery pack away from children.

- > Battery pack is heavy! Lifting equipment is recommended.
- > Do not touch the internal components when it's running. Ensure that the power switch and the breaker of the battery pack are always turned off prior to all installation, replacement, and maintenance processes.
- > Read this entire document before installing or using battery. If operating the battery out of the specified conditions and requirements can result in high dangers of electrical shock, serious injury, or even death.
- > Use battery pack only as directed

CAUTION

Indicates a hazardous situation which, if not avoided, could result in minor injury or damage to the equipment.

- > Risk of electric shock. Do not remove the cover, there are no user serviceable parts inside. Refer to qualified personnel.
- > When the PV array is exposed to light, it supplies a DC voltage to this equipment.
- > Do not use cleaning solvents to clean battery pack, or expose battery to flammable or harsh chemicals or vapors.
- > Do not place battery pack in storage condition for more than one month, or permit the electrical feed on the battery pack to be severed. Please reach out to your installer for more information if needed.

1.3 Personal Protective Equipment

Wear the following safety equipment properly to perform installations. Installers must meet the relevant requirements of standards, such as IEC60364, or local laws.



Safety goggles



Ear plugs



Insulated gloves



Safety gloves



Safety shoes

1.4 Contact information

Web: www.johnrayenergy.com

Email: info@johnrayenergy.com

Address: Room 209, Building 1, Lejiahui Business Plaza, New District, Suzhou, Jiangsu, China

2

Product Introduction

2.1 Battery pack overview

The battery pack is a high voltage smart series lithium battery which consists of long span LiFePO4 battery cells and functional BMS. It can store and release electric energy based on the requirements of the inverter. It is mainly for home energy storage system or small commercial industries.

NOTE:

JRH25 battery pack can extend to maximum 10 battery module boxes but working normal need at least 4 battery module boxes.

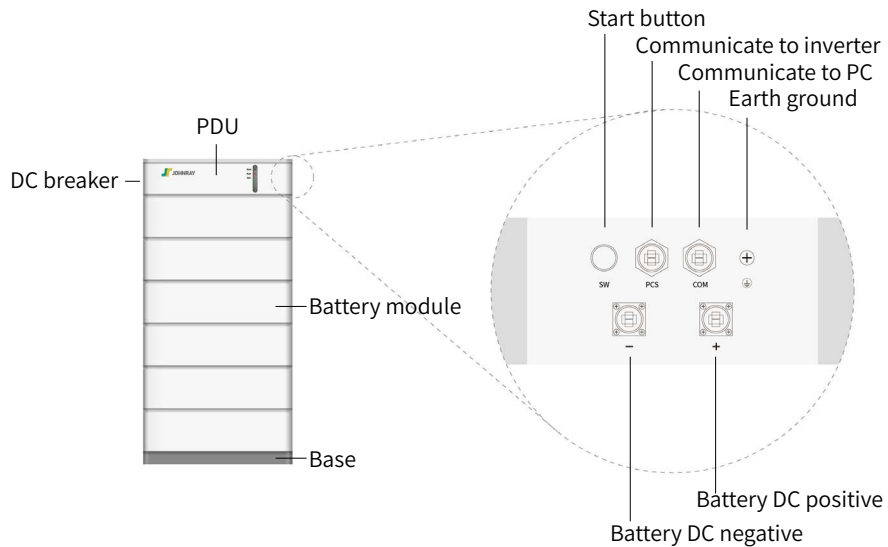

Key Features

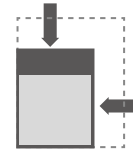

Compact size & Easy Installation

The lightweight and stackable design allows easier and faster installation indoor.



Safety

The battery pack use LFP cell to store energy, built-in BMS monitor its operation and prevents the battery from operating outside of design limitations.

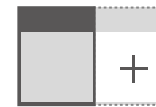

Expandability

The battery pack capacity can be increased by adding battery modules.



High compatibility

The battery pack is compatible with a wide range of inverters.



Remote wake up

Johnray brand inverter can remotely wake up the sleep battery pack, this is a very important and useful function.

System design

JRH25 battery pack is a high voltage rechargeable home battery system designed to maximize your home's energy independence, and potentially savings on your electricity bill.

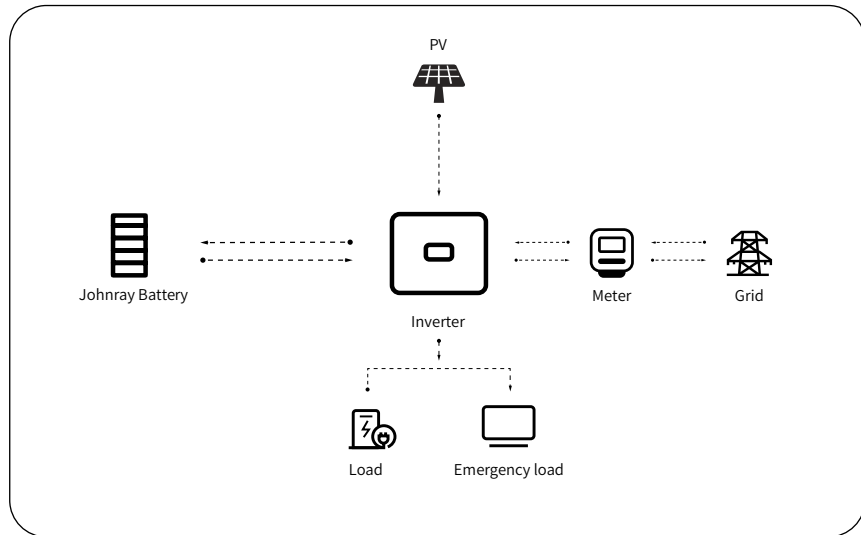
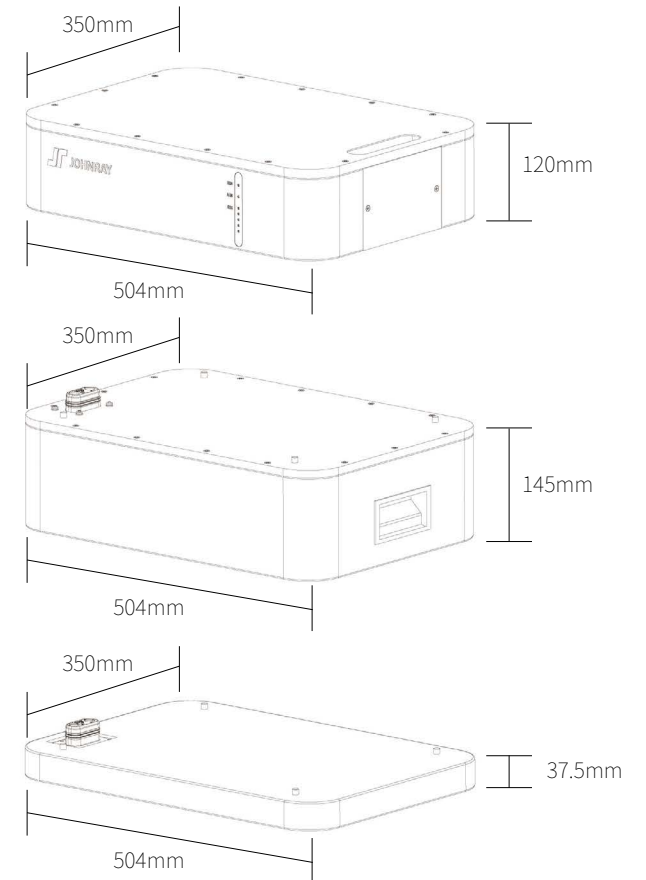

Figure1: The battery pack working with JOHNRAY high voltage three phase hybrid inverter.

2.2 Technical data

2.2.1 Dimensions and weight

	Length(mm)	Width(mm)	Height(mm)	Weight(kg)
Base	504	350	37.5	5.5
Battery module	504	350	145	26.3
PDU	504	350	120	11.5



2.2.2 Performance

Electrical Specifications

Model	JRH25-S4	JRH25-S5	JRH25-S6	JRH25-S7	JRH25-S8	JRH25-S9	JRH25-S10
Nominal Energy:	10.24 kWh	12.8 kWh	15.36 kWh	17.92 kWh	20.48kWh	23.04kWh	25.6 kWh
Nominal Voltage:	204.8V	256V	307.2V	358.4V	409.6V	460.8V	512V
Nominal Capacity:	50Ah						
Modules:	4+PDU	5+PDU	6+PDU	7+PDU	8+PDU	9+PDU	10+PDU
Connection:	1P64S	1P80S	1P96S	1P112S	1P128S	1P44S	1P160S
Operating Voltage Range:	172.8-230.4V	216.0-288.0V	259.2-345.6 V	302.4-403.2V	345.6-460.8V	388.8-518.4V	432.0-576.0V
Max.Charge/Discharge Current:	26 A/35A						
Charge/Discharge Temperature:	0~55°C / -10~55°C						
Ingress protection Rating:	IP20						
Cooling Method:	Natural Cooling						
Recommended dod:	85%						
Cycle Life:	>6000 Cycles (85% DOD/25C@0.5C)						
Communication:	CAN						
Certifications:	Reach,CE,CB,RoHS,IEC62477,IEC61000,IEC62619,UN38.3						
Dimensions(LxWxH):	504x350x(737.5/ 882.5/1027.5/1172.5/1317.5/1462.5/1607.5)mm						
Weight:	123±1kg	148±1kg	175 ±1kg	201±1kg	227±1kg	254±1kg	280±1kg

2.2.3 Environment requirement

JRH25

Operating Temperature Range	0~55° C
Optimal Operating Temperature	5~50° C
Storage Temperature Range	-20~45° C
Humidity	5 to 95%
Altitude	Max 3000m
Cooling Strategy	Natural convection

2.2.4 Cable requirement

Power negative cable	φ16mm ²
Power positive cable	φ16mm ²
Communicate cable	φ3mm ²
Ground electrode	φ2.5mm ²

WARNING

Above cables have been prepared in package, unqualified cable may cause something serious.

3

INSTALLATION

3.1 Preparation

3.1.1 Installation material and tool

Make sure all necessary tools and materials are available before starting the installation process to avoid any inconvenience on site.

These tools are required to install battery pack.



Torque screwdriver



Phillips-screwdriver bit



Hex-key bit



Phillips-head screwdriver



Flat-head screwdriver



Torque wrench



Wire stripper



Cable crimper



Voltmeter

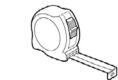

Tape measure



Drill



Sealant gun

3.1.2 Location survey

Make sure that installation location meets the following condition:

- > It is highly recommended that position at least more than 1000m away from sea to avoid salt water and humidity.
- > The floor must be flat and level.
- > There are no flammable or explosive materials nearby.
- > The optimal ambient temperature is between 15°C and 30 °C .

3.1.3 Package Examine

Verify and make sure that the following quantities are correct per placed order, and that no parts are broken or damaged during transportation. You may check off the unpacking inspection guide provided below.

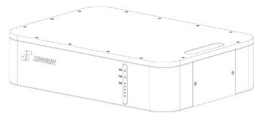

Battery module

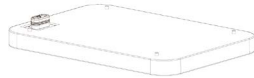

Base



Ground electrode cable



Red Power cable



Black power cable



RJ45 Communication cable

3.2 Start Installation

3.2.1 Installation Space

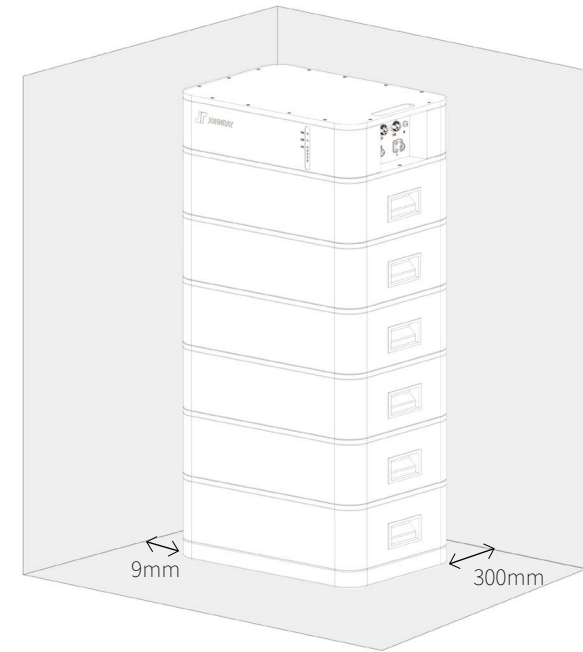

NOTE:

Make sure that the battery pack is always exposed to the ambient air, the battery pack is cooled by natural convection. If the battery pack is entirely or partially covered or shielded, it may cause the battery pack to stop operating.

3.2.2 Stack battery pack

Examine and ensure that the following quantities are correct per placed order, and that no parts were broken or damaged during transportation. You may check off the unpacking inspection guide provided below.

step 1

> Place the base on the floor

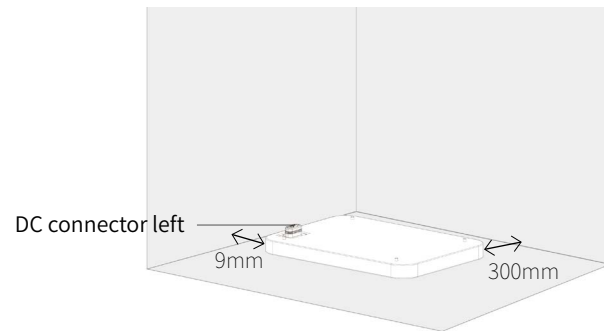

NOTE:

JRH25 battery pack only floor mount.

! WARNING

Make sure floor is flat, level tool is needed, keep away from water accumulation.

step 2

> Place the battery module on the top of base, Repeat step 2 stack the required number of battery modules on top of the base according to the configuration. Finally place the PDU box on the top.

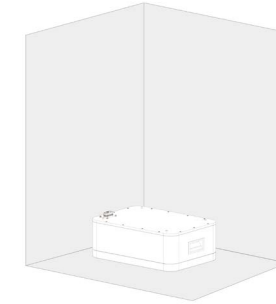

NOTE:

Big space between upper box and down box is forbidden, please press down until space disappear. Because out of contact between battery modules may cause heat even fire in running.

step 3

> Finally place the PDU box on the top.

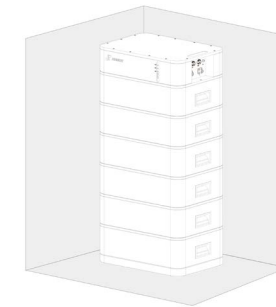

NOTE:

DC breaker switch is located OFF position, before putting PDU on the last battery module.

3.2.3 Cable connection

⚠ WARNING

Make sure that the inverter is turned off before connecting the battery pack to the inverter.

- > Remove the cable cover on the right side.
- > Connect Red Power cable to “+” port and Black power cable to “-” port.
- > Connecting RJ45 Communication cable to the “PCS” port.
- > Connecting Ground electrode to “ \perp ” port.

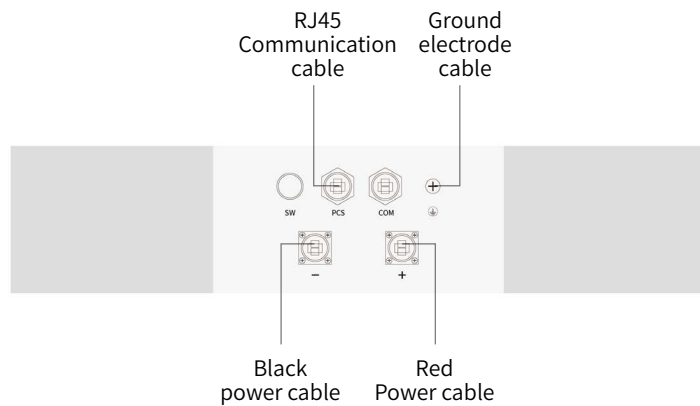

NOTE:

Pay attention not to reverse polarity. Connection with reversed polarity causes severe damage to the battery pack.

NOTE:

It is required for the battery back to communicate with the inverter for proper operation.

4

COMMISSIONING

4.1 Status Indicator



There are seven LED indicators on the front of battery pack to show its operating status.

RUN: This indicator stays on while the battery pack running normally, including charge and discharge.

ALM: This indicator comes on when the battery pack is in an alarm state.

SOC: There are five indicators to indicate different levels of SOC.

4.2 Power on battery pack

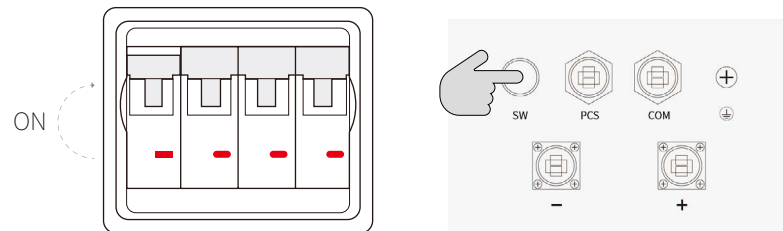

- > Move the DC breaker switch to ON position.
- > Press the “SW” button for 5 seconds to turn on the battery pack.

NOTE:

If communication with inverter is not established within 3 minutes after the battery pack is turned on, the output power from battery pack will close off. At the same time, RUN indicator will close off, while ALM indicator stay on.

4.3 Shutting down battery pack

- > Move the DC breaker switch to OFF position.

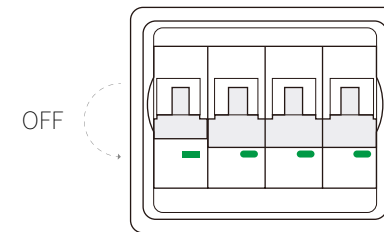

NOTE:

Make sure all of indicators on the battery pack be off.

5

Troubleshooting

Check the indicators on the front to determine the state of battery pack. A warning state is triggered when a condition, such as voltage, current or temperature, is beyond design limitations.

Use monitor software connected to battery pack to identify what has caused the warning, the possible warning message are as follows:

- Battery over voltage
- Battery under voltage
- Battery over temperature
- Battery under temperature
- Battery discharge over current
- Battery charge over current
- BMS internal communication error
- Battery cell voltage imbalance

NOTE:

System can recover minor risk hazardousless warnings automatically after a while. For critical warning or alarm, please contact JOHNRAY service team or local installers.

User Manual



Suzhou Johnray Solar Energy Co., Ltd

 Room 209, Building 1, Lejiahui Business Plaza, New District, Suzhou, Jiangsu, China

 +86(0)512 65100899

 info@johnrayenergy.com