

User Manual



V1.2

CONTENTS

1 NOTES ON THIS MANUAL	1
1.1 VALIDITY	1
1.2 SYMBOLS IN THIS DOCUMENT	1
2 OVERVIEW	3
2.1 PRODUCT INTRODUCTION	3
2.2 APPEARANCE	3
3 INSTALLATION	3
3.1 CHECK FOR PHYSICAL DAMAGE	4
3.2 PACKING LIST	4
3.3 MOUNTING	4
3.4 SPACE REQUIREMENT	4
3.5 MOUNTING STEPS	4
4 ELECTRICAL CONNECTION	9
4.1 PV CONNECTION	11 -
4.2 BATTERY CONNECTION	15
4.3 ON-GRID& BACK-UP CONNECTION	15
4.4 COMMUNICATION CONNECTION	15
5 POWERING ON THE SYSTEM	20
5.1 START-UP THE INVERTER	20
5.2 FIRST RUN TIME SETTING	20
6 POWERING OFF THE SYSTEM	20
7 LCD OPERATION	20
8 MAINTENANCE AND CLEANING	21
8.1 MAINTAIN PERIODICALLY	31

8.2 TROUBLE SHOOTING	31
9 DECOMMISSIONING	31
9.1 REMOVE THE INVERTER	34
9.2 PACKAGING	34
9.3 STORAGE AND TRANSPORTATION	34
10 TECHNICAL DATA	34
11 APPENDIX	37
12 MANUFACTURER WARRANTY	38
13 CONTACT	38

1 Notes on this manual

1.1 Validity

This manual describes the assembly, installation, commissioning and maintenance of the following Johnray hybrid inverters model:

JH-3K-ML

JH-3.6K-ML

JH-4K-ML

JH-5K-ML

JH-6K-ML

Target Group

This manual is for qualified personnel. Qualified personnel have received training and have demonstrated skills and knowledge in the construction and operation of this device. Qualified Personnel are trained to deal with the dangers and hazards involved in installing electric devices.



Additional information



Find further information on special topics in the download area at www.johnrayenergy.com

The manual and other documents must be stored in a convenient place and be available at all times. We assume no liability for any damage caused by failure to observe these instructions. For possible changes in this manual, Suzhou Johnray Solar Energy Co., Ltd. accepts no responsibilities to inform the users.









1.2 Symbols in this document

Please pay close attention to all the symbols for the purpose of avoiding possible personal injury or equipment break down.

Symbol	description
 DANGER	DANGER indicates a hazardous situation which, if not avoided, will result in death or serious injury.
 WARNING	WARNING indicates a hazardous situation which, if not avoided, could result in death or serious injury.

 CAUTION	CAUTION indicates a hazardous situation which, if not avoided, could result in minor or moderate injury.
 NOTICE	NOTICE is used to address practices not related to personal injury
 Information	Information that you must read and know to ensure optimal operation of the system.

Markings on this product

Symbol	Explanation
	Caution, risk of electric shock
	Caution, hot surface
	Operation after 5 minutes
	Read the manual
	Point of connection for grounding protection
	CE mark. The inverter complies with the requirements of the applicable CE guidelines.
	The inverter must not be disposed of with the household waste.
 <p>WARNING</p> <p>Internal high voltage. To avoid electric shocks, perform the follow steps before plugging or unplugging DC connector:</p> <ol style="list-style-type: none"> 1. Turn off the AC switch. 2. Turn off the DC switch. 3. Do not disconnect under load! 4. Different brands of connector are forbidden to together. 	Warning, high voltage.

2 Overview

2.1 Product Introduction

Function

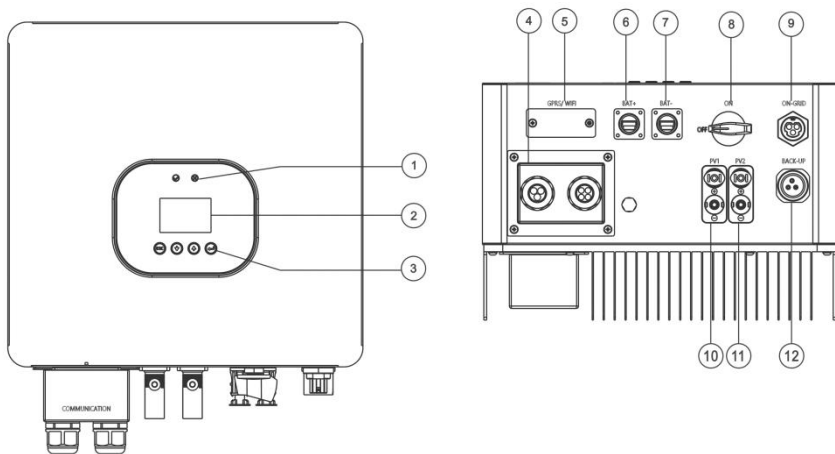

JH-3/6K-ML series, also called hybrid or bidirectional solar inverters, apply to solar system with participation of PV, battery, loads and grid system for energy management. The energy produced by PV system shall be used to optimize self-consumption, excess power charge battery and the rest power could be exported to the grid. Battery shall discharge to support loads when PV power is insufficient to meet self-consumption. If battery power is not sufficient, the system will take power from grid to support loads.

2.2 Appearance







- ① LED indicator ② LCD display ③ Function button ④ Communication port
- ⑤ GPRS/WIFI output port ⑥ Battery Terminals (+) ⑦ Battery Terminals (-) ⑧ DC switch
- ⑨ On-Grid Port ⑩ DC input terminals (PV1) ⑪ DC input terminals (PV2) ⑫ Back-Up Port

LED indicator description

Category	Status	Meaning
 LED 1	Green light on	Normal status
	Green light blinking	Alarm status
 LED 2	Red light on	Fault status
	Blinking red at short intervals	Software updating

Function button description

Category	Description
	ESC button: Return from current interface or function.
	Down button: Move cursor to downside or decrease value
	Up button: Move cursor to upside or increase value.
	OK button: Confirm the selection.

3 Installation

3.1 Check for Physical Damage

Make sure the inverter is intact during transportation. If there is any visible damage, such as cracks, please contact your dealer immediately.

3.2 Packing List

Open the package and take out the product, please check the accessories first.

The packing list shown as below.

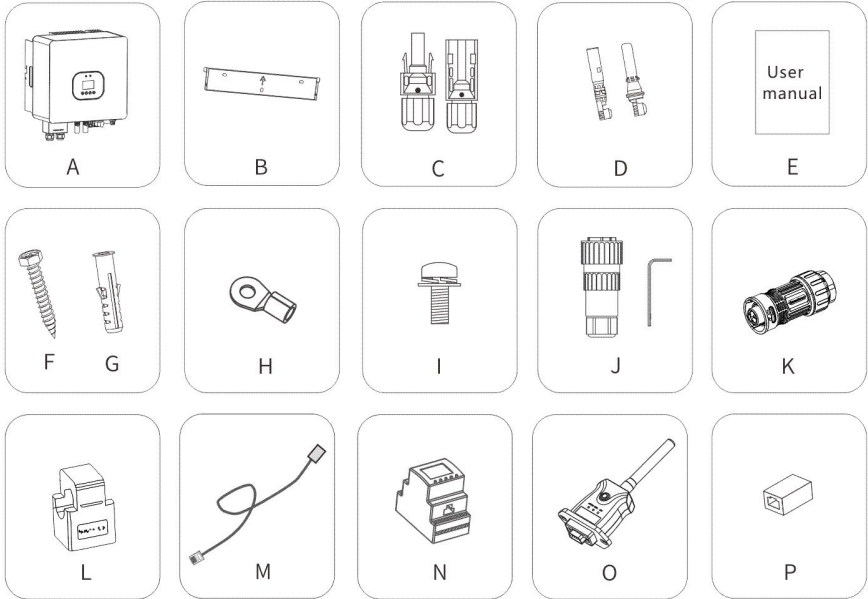

Object	Description	Quantity
A	Inverter	1
B	Bracket	1
C	PV connectors (2*positive,2*negative)	2/2
D	PV pin connectors (2*positive, 2*negative)	2/2
E	User manual	1
F	Expansion tubes	3
G	Expansion screws	3
H	Ring terminal	1
I	Set screw(for mounting, external enclosure grounding)	3
J	On-grid output connector	1
K	Back-up connector	1
L	CT	1
M	Lead-acid battery temperature sensor	1
N	Meter (optional)	1
O	Wifi module (optional)	1
*P	RJ45 connector	1

* P:When the length of CT wire cannot meet the use requirements, the CT communication wire can be extended through RJ45 connector.

3.3 Mounting

Installation Precaution

JH-3/6K-ML series inverter is designed for outdoor installation (IP 65).

Make sure the installation site meets the following conditions:

- ◆ Not in direct sunlight.
- ◆ Not in areas where highly flammable materials are stored.
- ◆ Not in potential explosive areas.
- ◆ Not in the cool air directly.
- ◆ Not in environment of precipitation or humidity (> 95%).
- ◆ Under good ventilation condition.
- ◆ The ambient temperature in the range of -20°C to +60°C.
- ◆ The wall hanging the inverter should meet conditions below:
 1. Solid brick/concrete, or strength equivalent mounting surface;
 2. Inverter must be supported or strengthened if the wall's strength isn't enough (such as wooden wall, the wall covered by thick layer of decoration).

Please avoid direct sunlight, rain exposure, snow laying up during.



◆ The slope of the wall should be within 15°.

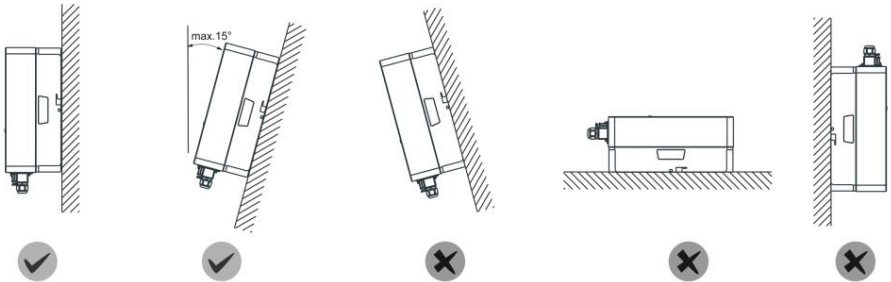

3.4 Space Requirement

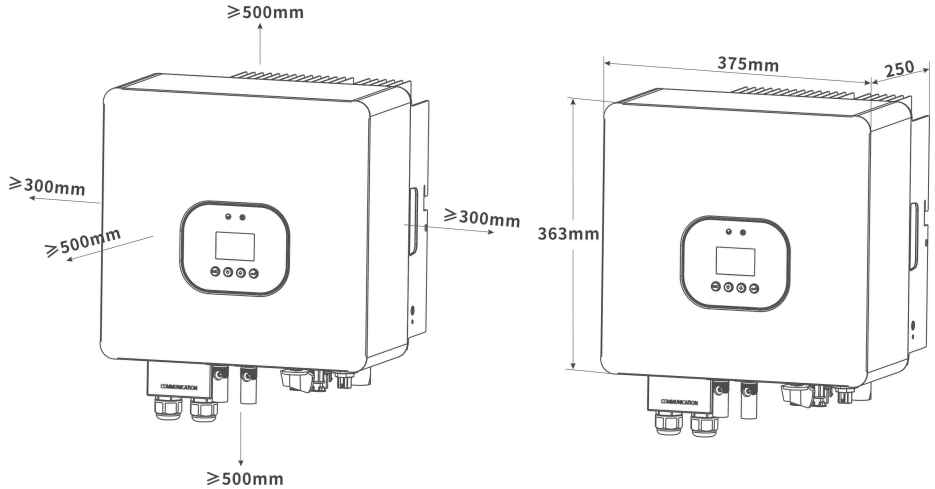

3.5 Mounting Steps

1. Use the wall bracket as a template to mark the position of the 3 holes on the wall.
2. Drill holes with driller, make sure the holes are deep enough (at least 60mm) for installation, and then tighten the expansion tubes.
3. Install the expansion tubes in the holes, and tighten them. Then install the wall bracket by using the expansion screws. ($\Phi 10$ driller, torque: $2.5 \pm 0.2 \text{ Nm}$)
4. Hang the inverter over the bracket, move the inverter close to it, slightly lay down the inverter, and make sure the 2 mounting bars on the back are fixed well with the 2 grooves on the bracket.
5. After confirming the inverter is fixed reliably, fasten two M5 safety-lock sockets head cap screws on the right or left side firmly to prevent the inverter from being lifted off the bracket (torque: $2.0 \pm 0.2 \text{ Nm}$)

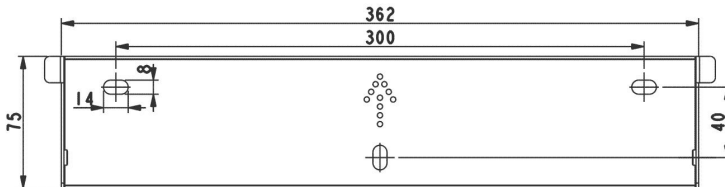

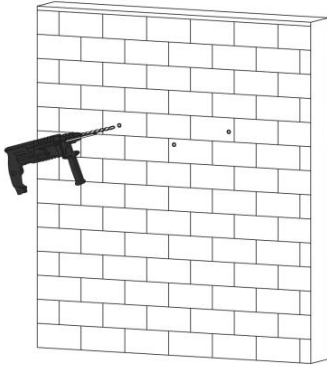

①

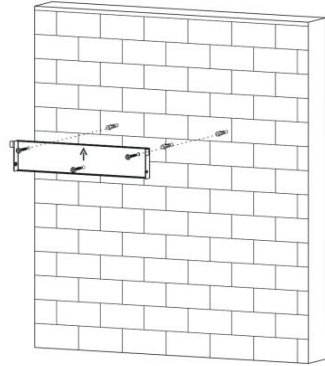

②

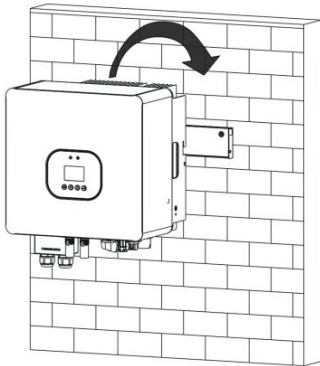

③

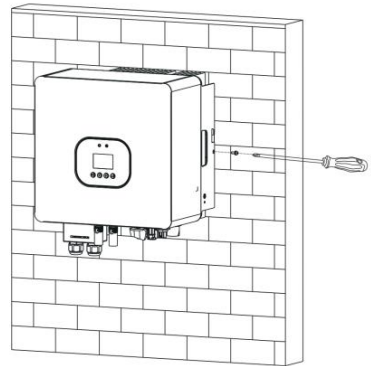

④

4 Electrical Connection



◆ For Australian safety country, the neutral cable of On-Grid side and Back-Up side must be connected together, otherwise Back-Up function will not work.

System connection diagrams

This diagram is an example for Australian and New Zealand grid system.

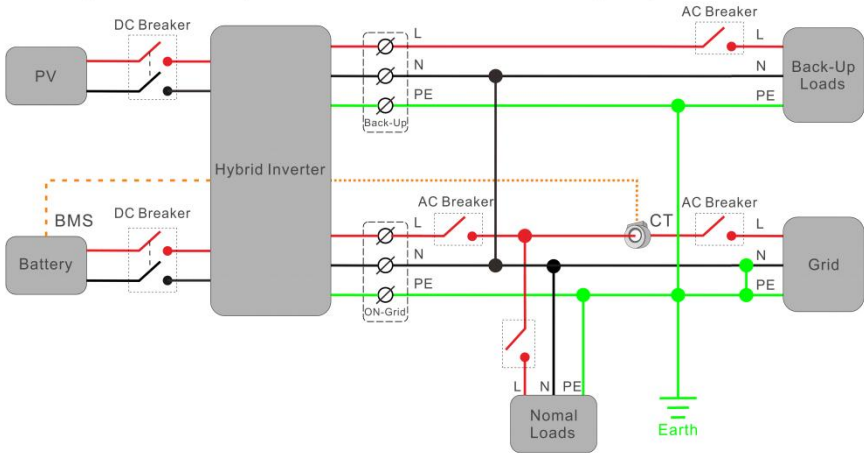

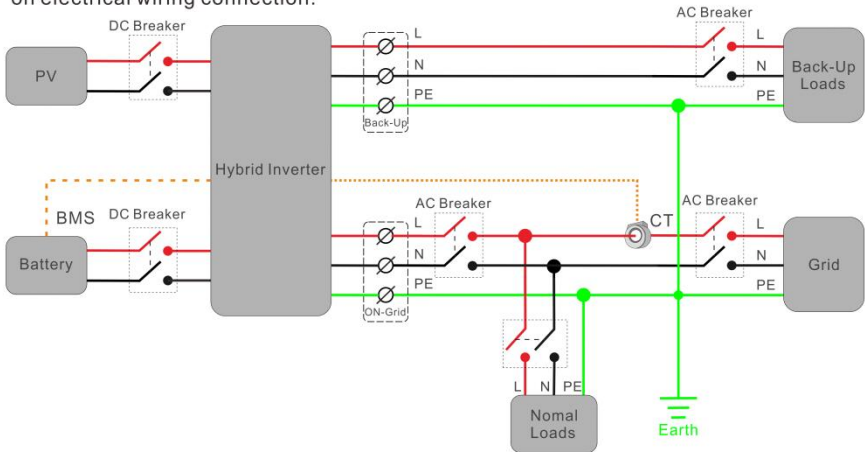

This diagram is an example for grid systems without special requirement on electrical wiring connection.





4.1 PV connection

◆ Conditions for DC Connection

The inverter has 2 independent input : PV1 & PV2 Notice that the connectors are in paired (male and female connectors). The connectors for PV arrays and inverters are H4 connectors;

 DANGER	The solar modules connected to the inverter must conform to the Class A requirements of the IEC 61730 standard.		
 CAUTION	If the inverter is not equipped with a DC switch but this is mandatory in the country of installation, install an external DC switch. The following limit values at the DC input of the inverter must not be exceeded:		
	Model	Max current PV1	Max current PV2
	3K-6K	15A	15A

◆ Connecting the PV Array

 DANGER	Danger to life due to lethal voltages! ◆ PV array supplies d.c voltage to inverter when exposed to light, before connecting the PV array, cover some light screens above PV arrays, ensure that the DC switch and AC breaker are disconnect from the inverter. NEVER connect or disconnect the DC connectors under load. ◆ Make sure the maximum open circuit voltage (Voc) of each PV string is less than the maximum input voltage of the inverter. ◆ Check the design of the PV plant. The Max. open circuit voltage, which can occur at solar panels temperature of -10°C , must not exceed the Max. input voltage of the inverter.
 CAUTION	◆ Improper operation during the wiring process can cause fatal injury to operator or unrecoverable damage to the inverter. Only qualified personnel can perform the wiring work. ◆ Please don't connect PV array positive or negative pole to the ground, it could cause serious damages to the inverter ◆ Check the connection cables of the PV modules for correct polarity and make sure that the maximum input voltage of the inverter is not exceeded

Connection Steps:

1. Choose the 12 AWG wire to connect with the cold-pressed terminal.
 2. Remove 7mm of insulation from the end of wire.
 3. Insert the insulation into pin contact and use crimping plier to clamp it.
 4. Insert pin contact through the cable nut to assemble into back of the male or female plug.
- When you feel or heard a "click" sound the pin contact assembly is seated correctly.
5. Plug the PV connector into the corresponding PV connector on inverter.

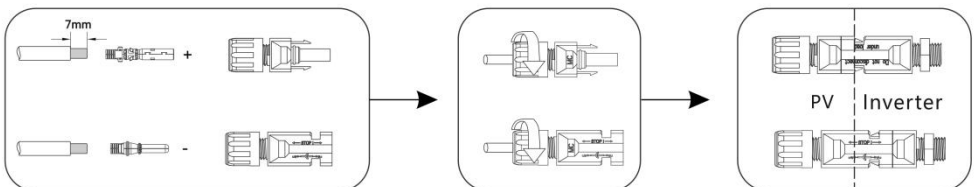

4.2 Battery Connection

- ◆ Lead-Acid and other similar older-technology battery types require experienced and precise design, installation and maintenance to work effectively. For lead-acid battery bank, the inconformity between battery cells might lead to battery cell over-charge or discharge, and further might damage battery cells and shorten battery bank life.
- ◆ For lithium battery (pack) the capacity should be 50Ah or larger. Battery cable requirement as below.

Table 1 Cable recommended

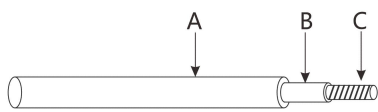
	A	O.D	10-12mm
	B	Isolation section	NA
	C	Area	20-25mm ²

- ◆ Please be careful against any electric shock or chemical hazard
- ◆ Make sure there is an external DC switch ($\geq 125A$) connected for battery without build-in DC switch.

Battery wiring connection steps as below:

 CAUTION	<ul style="list-style-type: none"> ◆ Make sure battery switch is off and battery nominal voltage meet specification before connecting battery to inverter and make sure inverter is totally isolated from PV and AC power. ◆ Please make sure polarity (+/-) of battery are not reversed.
--	---

1. Prepare battery cables and accessories and put battery power cable through battery cover. Compress the terminal head by using a crimping pliers.
2. Connect battery terminals onto inverter .
3. Tighten screws.
4. Tighten the screw cap.

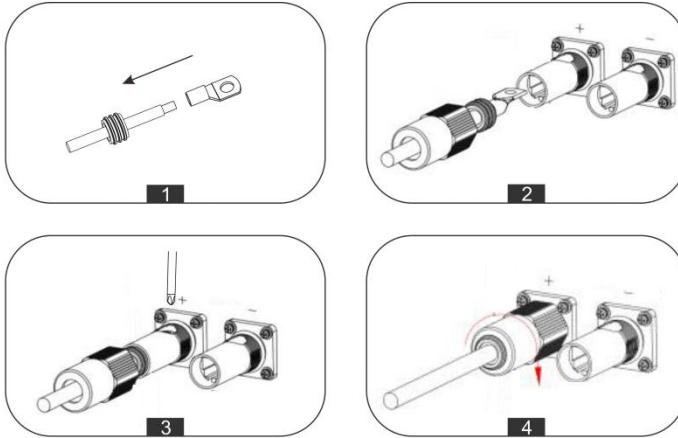

4.3 On-Grid & Back-UP Connection

An external AC switch is needed for on-grid connection to isolate from grid when necessary.

 CAUTION	<p>◆ Make sure inverter is totally isolated from any DC or AC power before connecting AC cable.</p>
--	---

Connection Steps

1. Choose the appropriate wire, Wire Stripping (Cable size: refer to Table).
2. Set the parts on the cable one by one.
3. Wire crimping cord end terminal can be inserted into the housing quickly according to the sign.
4. Insert Seal and Clamp Finger into socket, then tighten the nut.

On-Grid Connection:

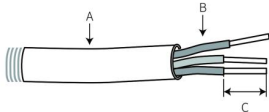
	A	Diameter	13-18mm
	B	Area	10mm ² or 8AWG
	C	Length	11mm

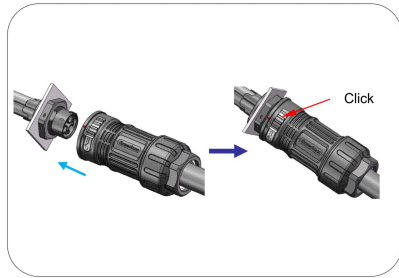
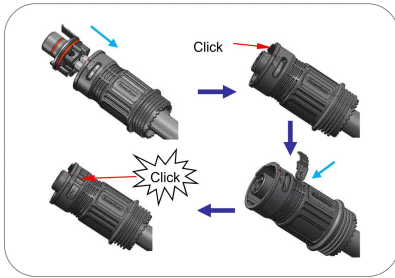
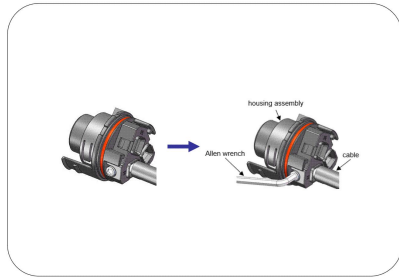
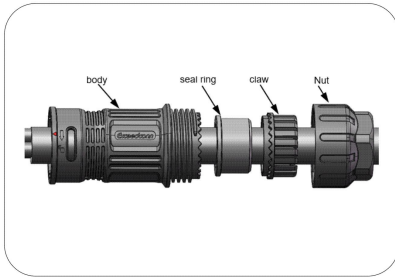

Back-UP Connection

	A	Diameter	10-14mm
	B	Area	6mm ² or 10AWG
	C	Length	10mm

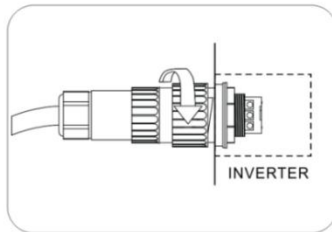
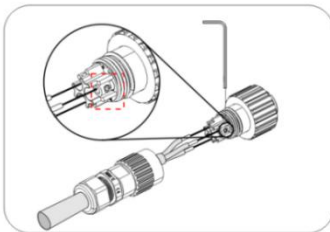
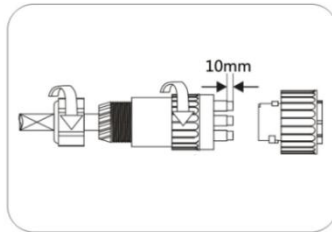
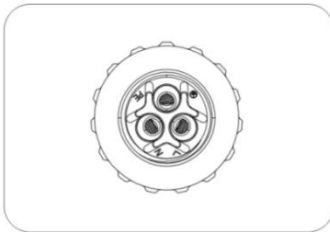

4.4 Earth Connection

Users must additionally earth the inverter to the enclosure of a second earthing or equipotential bonding . This prevents electric shock if the original protective conductor fails.

Earth Connection Steps:

1. Strip the earthing cable insulation and insert the stripped cable into the ring terminal, then clamp it .
2. Place the ring terminal into the earthing rod and screw the earthing screw tightly.

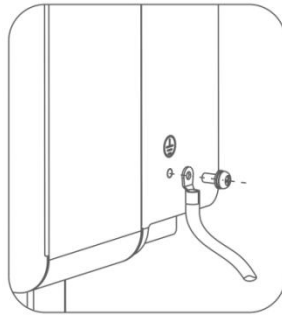

4.5 Communication Connection

1.Function port definition

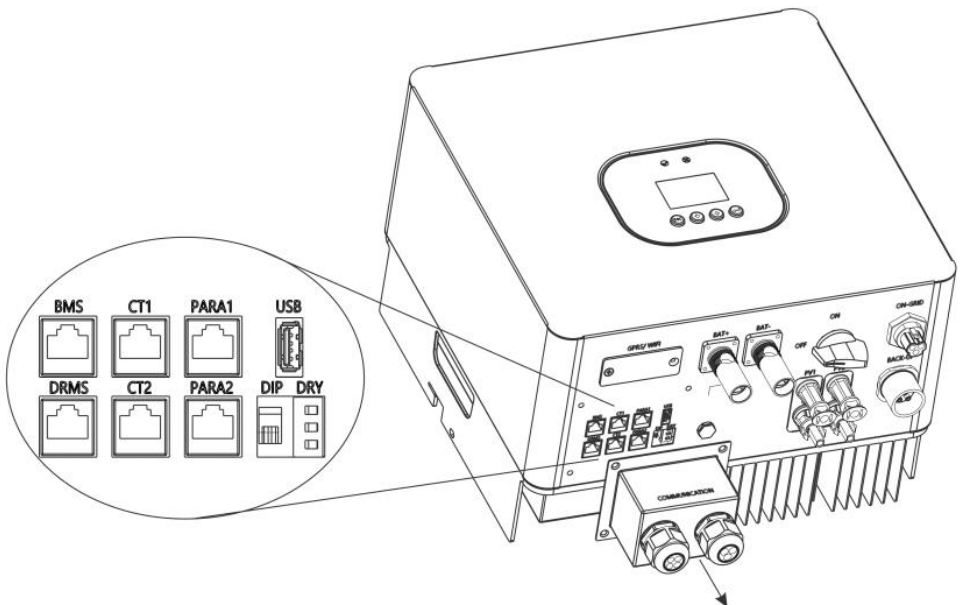

Object	Category	Description
1	BMS	RS485/CAN/NTC port for battery communication
2	DRMS	For Australia market only
3	CT1	Current transformer port1/ Meter communication port
4	CT2	Reserve
5	PARA1	Reserve
6	PARA2	Reserve
7	USB	Upgrade firmware program port
8	DRY	External devices communication port
9	DIP	DIP Switch

- ◆ Make sure use standard RJ45 cable and plug, as below



Pin	BMS	CT1	DRMS
1	RS485B	CT1_RS485B	DRM1/5
2	RS485A	CT1_N	DRM2/6
3	GND-S	CT1_N	DRM3/7
4	CANH	GND-S	DRM4/8
5	CANL	CT1_RS485A	DRM_REF
6	NTC.BAT	CT1_P	DRM_COM
7	Wake-	CT1_P	RS485A
8	Wake+	CT1_ON+	RS485B

2.CT1 Connection

- ◆ The CT in product box is compulsory for inverter system installation, used to detect grid voltage and current direction and magnitude, further to instruct the operation condition of inverter via RS485 communication.

 CAUTION	◆ Make sure inverter is totally isolated from any DC or AC power before connecting AC cable. ◆ Direction of the CT cannot be connected in reverse, please follow "K→L" direction to do the connection. Make sure CT are connected between loads and grid.
--	--

CT Connection Diagram:

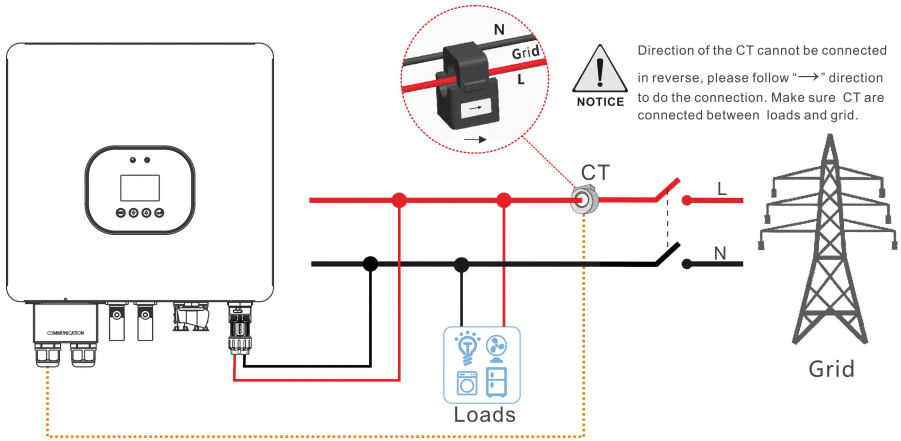

Connection Steps:

1. Uninstall the “CT” cable from the accessory bag.
2. Thread the “CT” cable through the cable gland.
3. Insert the RJ45 plug of the network cable into the “CT1” pin connector on the inverter until it snaps into place. the completed appearance is like the below figure.

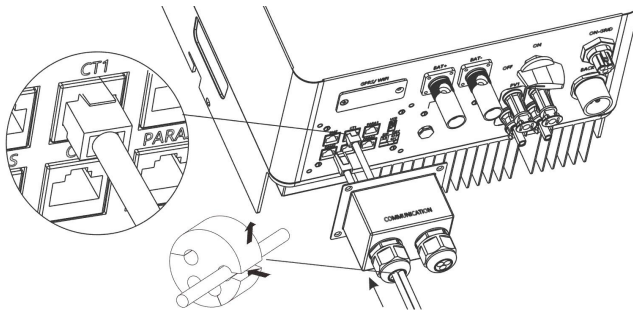

3. Meter Connection (optional)

- ◆ The meter is optional, used to detect grid voltage and current direction and magnitude, further to instruct the operation condition of inverter via RS485 communication.

Meter Connection Diagram:

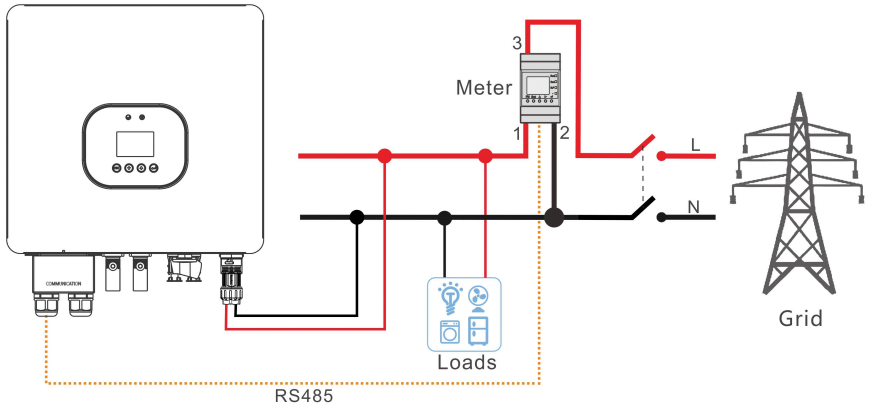

Description	CT1-Pin	Meter-Pin
CT1_RS485B	1	25
CT1_RS485A	5	24

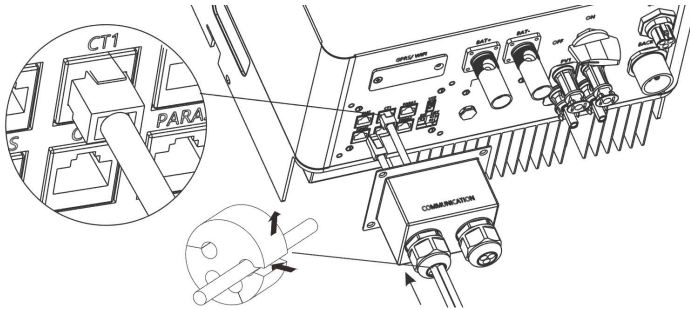

4.BMS Connection

- ◆ Using CAN or RS485 communication with lithium batteries.
- ◆ Using lead-acid batteries, a temperature sensor must be connected.

<p>CAUTION</p>	<ul style="list-style-type: none"> ◆ If you are using a lead-acid battery, you do not need to install CAN or RS485 communication. ◆ The CAN battery communication and RS485 battery communication can't be installed at same time.
----------------	--

Connection Steps:

- 1.Prepare communication cable.
- 2.Thread the “BMS” cable through the cable gland.
- 3.Insert the RJ45 plug of the network cable into the “BMS” pin connector on the inverter until it snaps into place. the completed appearance is like the below figure.

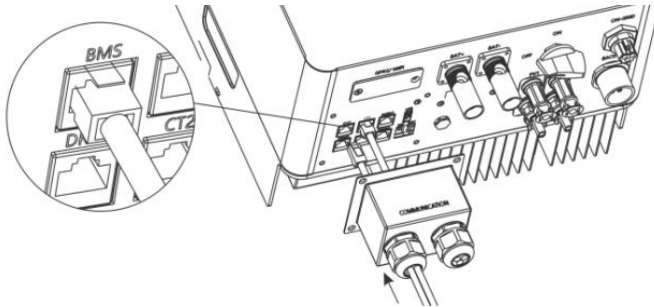
**5.DRED Connection**

◆ DRED is only for Australian and New Zealand installations, in compliance with Australian and New Zealand safety requirements. Detailed connection of DRED device is shown below:

Connection Steps:

- 1.Prepare communication cable.
- 2.Thread the “DRED” cable through the cable gland.
- 3.Insert the RJ45 plug of the network cable into the “DRED” pin connector on the inverter until it snaps into place. the completed appearance is like the below figure.

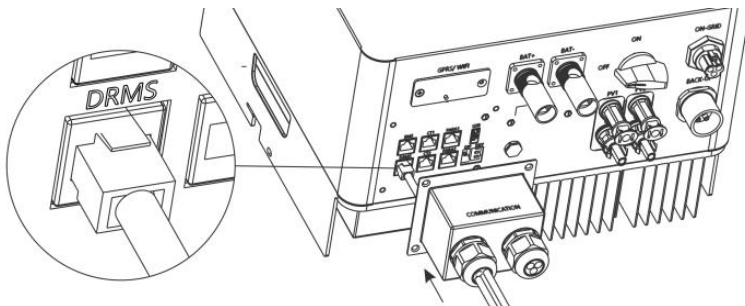

5 Powering On the System



Before turning on the AC switch between the inverter and the power grid, use a multimeter set to the AC position to check that the AC voltage is within the specified range.

5.1 Start-Up the inverter

1. Turn on the DC switch between the battery and the inverter.
2. Turn on the DC switch between the PV string and the inverter.
3. Turn on the DC switch at the bottom of the inverter.
4. Turn on the AC switch between the inverter and the power grid.
5. If the battery is lithium, turn on the switch on the battery.
6. Observe the LEDs to check the operating status of the inverter.

5.2 First run time setting

6 Powering Off the System



Do not disconnect the DC connectors under load.

Turn-off the inverter step:

1. Press and hold the "Enter" button for 3S to enter the shutdown interface and select "OFF".
2. Turn off the AC switch between the inverter and the power grid.
3. Turn off the DC switch between the PV string and the inverter.
4. Turn off the DC switch at the bottom of the inverter.
5. Turn off the DC switch between the battery and the inverter.
5. Check the inverter operating status.
6. Waiting until LED, OLED have go out, the inverter is shut down.

7 LCD Operation

The main interface is the default interface, the inverter will automatically jump to this interface when the system started up successfully or not operated for a period of time.

Menu interface

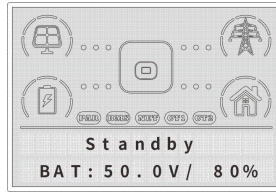

In normal, it will turn on page automatically, when pushing the button “UP”, the order of the paging information as follow:

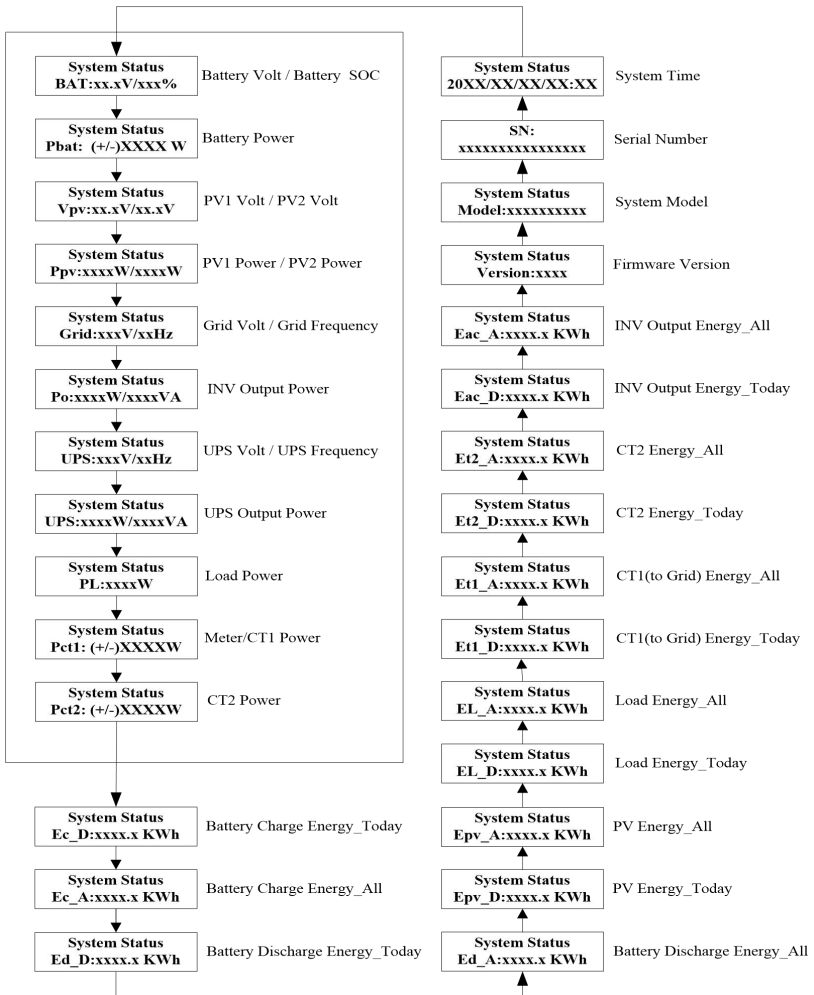

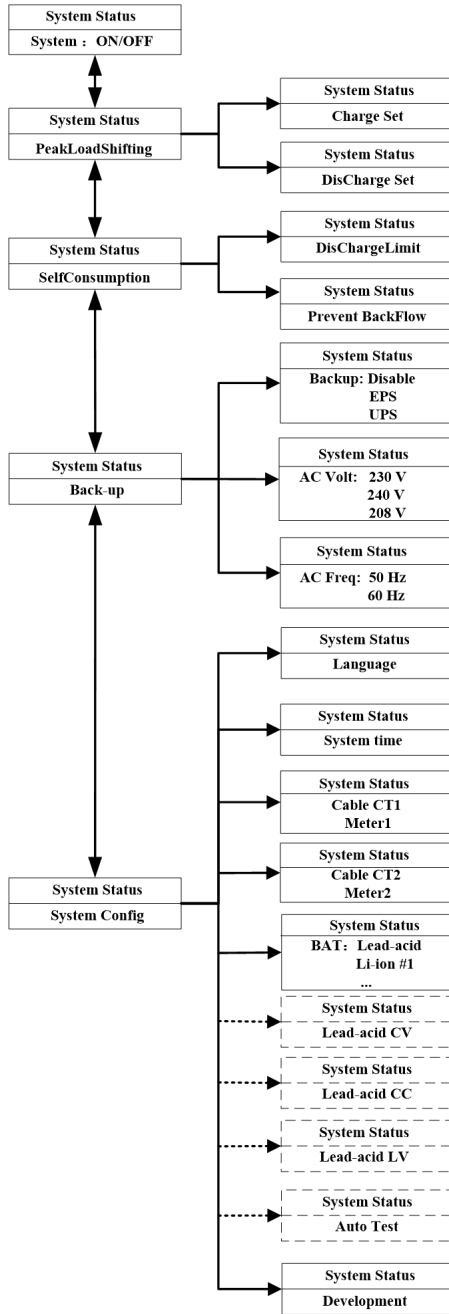

Long press (3s)

7.1 Enter Setting Interface



Press any key to light up the LCD, long press the "Enter" button for 5 seconds and then release it, user can enter to above setting interface, of which includes 5 types of setting contents.

The first interface is "System: ON/OFF" setting. The hybrid inverter will run automatically when it is powered on. And user can set the inverter to standby mode through this interface, "OFF" for standby mode and "ON" for operation mode.

7.2 Check and Set System Time

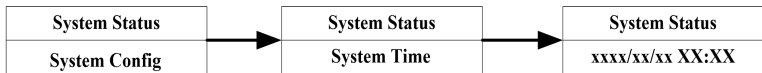

Use the "↑" or "↓" and "Enter" buttons to enter "System Config" to check or reset the system time.

If there is a data logger module connected, the server will automatically synchronize the inverter time. If the time is not set correctly, time settings for charging and discharging will be influenced.

7.3 Check and Set the Standard for Grid Connection

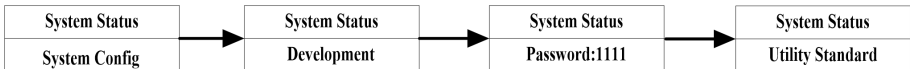

Use the "↑" or "↓" and "Enter" buttons to enter the grid standard screen in "System Config" to check or select the required grid standard. User need to long press "Enter" button for 5 seconds and then release it to enter the password verification screen to access "Development" interface

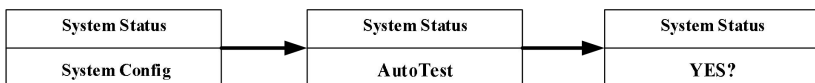

For example, if the grid connection standard is set to "CEI021", inverter will provide automatic self-test function. When the system is running, enter the "AutoTest" interface in "System Config". After setting to "YES" to confirm the selected grid connection standard, the system will automatically run tests as per standards. LCD screen will display test status. After the automatic self-test is completed, the system continues to operate normally.

7.4 Check and Set the Battery Type

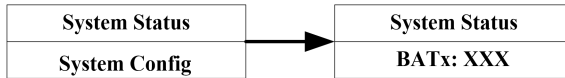

Use the "↑" or "↓" and "Enter" buttons to enter the "System Config " in the battery type screen. User can check and set the corresponding battery type through this page.

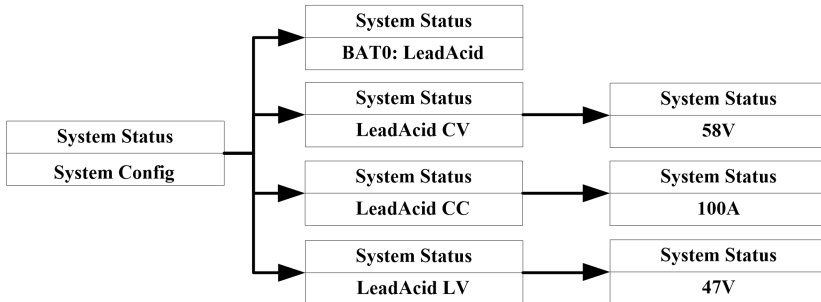

When using lead-acid battery, user need to connect NTC to the BMS communication port and stick the other end to the correct position of the lead-acid battery. And set the battery type to "BAT0:LeadAcid". Then set the parameters of CV constant voltage, CC constant current and LV under voltage point for the lead-acid battery.

Default parameters for CC, CV, LV, and adjustable parameter range.

CC: Default 100A, Range 0~120A, Maximum charge current of lead-acid battery.

CV: Default 58.0V, Range 55.0~59.2V, Constant voltage of lead-acid battery.

LV: Default 47V, Range 44~50V, Lead Acid Battery Stop Discharge Voltage

Before wiring, please pay attention that neither battery power line positive or negative cannot be reversed in the inverter battery port!

7.5 Check and Set the CT1 Type

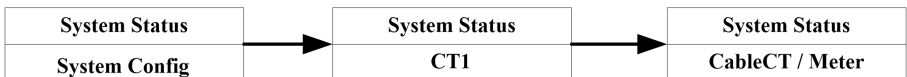

When the inverter is under self-consumption mode, user need to connect CT/meter to the CT1 port and also make sure that the other end of the CT/meter is connected to the grid in the correct direction. If CT/meter is not connected, inverter will report error.

Press "↑" or "↓" and "Enter" to enter the CT1 selection screen and check or set the CT1 option to CT or meter.

7.6 Check and Set CT2 Type (Optional)

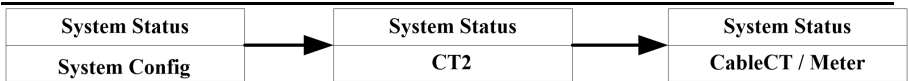

When an on-grid inverter is added to the energy storage system, a second CT/meter needs to be added so that the hybrid inverter can monitor the power generated by the on-grid inverter, thus, the load power and load power consumption can be measured correctly. Connect one end of the second CT/meter to the CT2 port, while the other end is connected to the output of the on-grid inverter.

Press "↑" or "↓" and "Enter" to enter the CT2 selection screen to check or set CT2 as CT or meter.

7.7 Check and Set Off-grid Parameters

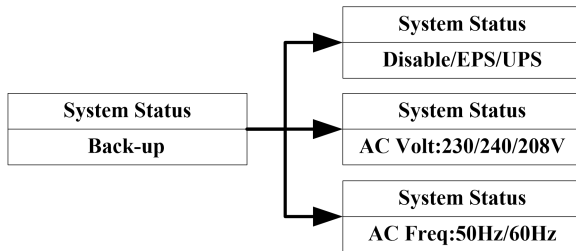

If the user needs to use the off-grid function when there is no utility power, the off-grid function should be turned on. Check and set the corresponding off-grid output voltage and frequency.

BackUp: Disable, off-grid function is not enabled. No output from the backup port when grid outage.

BackUp: EPS, when there is utility power, the backup port has no output; after utility power outage, the backup port will switch to EPS mode over 10ms . And output the "pre-set off-grid voltage and off-grid frequency".

BackUp: UPS, when utility power is available, the backup port is used as a utility bypass, outputting the same voltage and frequency as per the utility voltage and frequency. After a utility power failure, the backup port switches to UPS power mode within 10ms and outputs the "pre-set off-grid voltage and frequency".

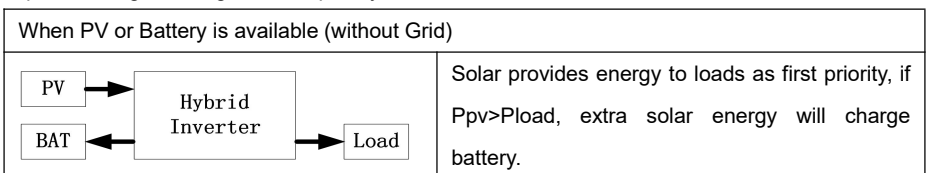

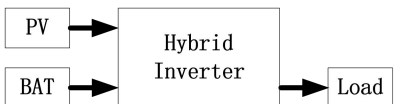
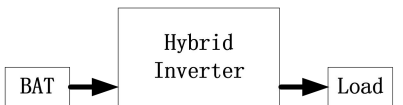
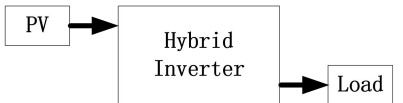
	<p>Solar provides energy to loads as first priority, if $P_{pv} < P_{load}$, battery energy and solar energy will supply to the loads at the same time.</p>
	<p>When PV is Off, battery energy will supply to the loads.</p>
	<p>When there is only PV, user can enable backup to UPS or EPS then PV will supply to the loads without battery and Grid for emergent use.</p>

7.8 Inverter Used Under Peakloadshifting Mode

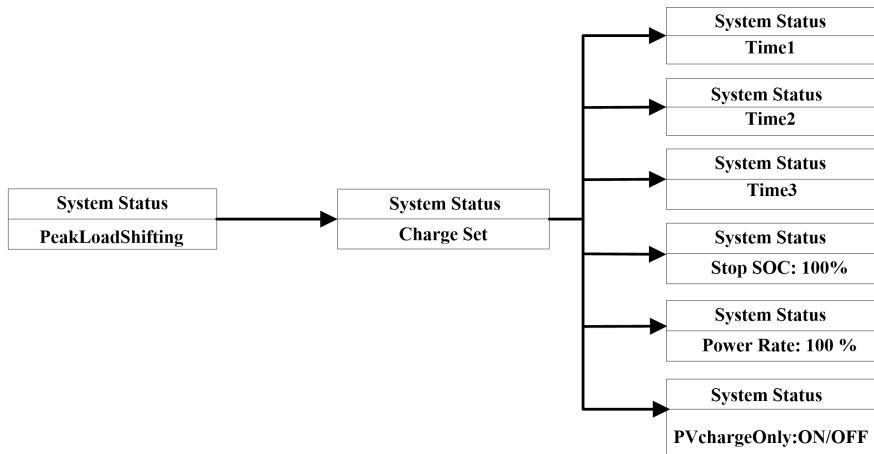



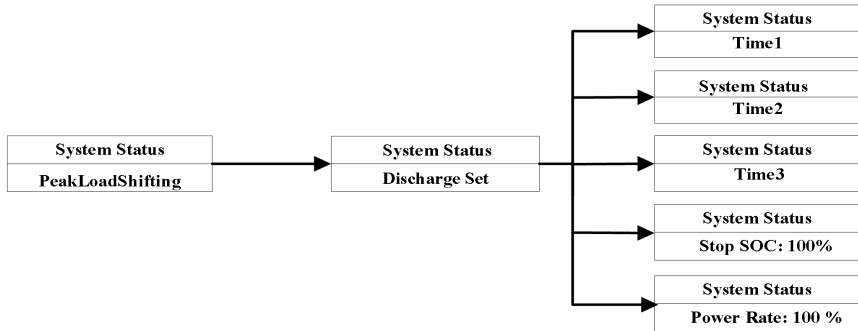

When the utility charging cost is low or the battery SOC is too low, user need to force the battery to be charged. Press "↑" or "↓" and "Enter" to enter the "Charge Set" interface in "PeakLoadShifting" to set and enable the charge start time and stop time. Then inverter will charge the battery according to the set charging power (Rated Battery Power*Power Rate) and stop charging when the charging SOC reaches "Stop SOC". If the PV is connected and the PV charge priority option "PVchargeOnly" is set to ON, the hybrid inverter charges the battery with PV power only without using the utility power during the charging time period.



When the selling price of electricity is high or the battery needs to be discharged, user can press "↑" or "↓" and "Enter" to enter the "Discharge Set" interface in "PeakLoadShifting" to set and enable the discharge start time and stop time. Then the inverter will discharge the battery according to the set discharge power (rated battery power*Power Rate) and stop discharging when the discharge SOC reaches "Stop SOC".

"Forced Charge or Forced Discharge Set" is provided with three separate time periods for setting. Users can force charge and force discharge the battery multiple times in one day, just make sure the force charge and force discharge times do not conflict. During the forced charging time period, the battery does not respond to the discharge demand of the load. However, during the forced discharge time period, if the PV power is greater than the rated inverter power, the excess energy of the PV automatically charges the battery.

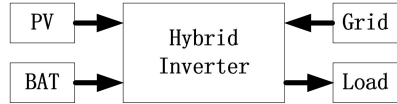
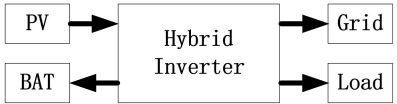
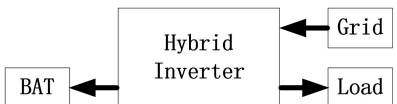
When PV, Grid, Battery is available	
	During charge time, solar energy will charge battery first. If $P_{pv} > P_{bat}$, extra solar energy will supply to the loads, and if $P_{pv} > (P_{bat} + P_{load})$, extra solar energy will feed in Grid.
	During charge time, solar energy will charge battery first. If $P_{pv} > P_{bat}$, extra solar energy will supply to the loads, and if $P_{pv} < (P_{bat} + P_{load})$, Grid will supply energy with solar together.

	During charge time, solar energy will charge battery first. If $P_{pv} < P_{bat}$, Grid will supply energy with solar together. But if $P_{pv} < P_{bat}$ and PVchargeOnly is On, the battery charging energy is only use solar energy, Grid energy will only supply for loads.
	During discharge time, solar energy and battery discharge energy provide power to the loads. If $(P_{pv} + P_{bat}) > P_{load}$, the extra energy will feed in Grid.
	During discharge time, solar energy and battery discharge energy provide power to the loads. If $(P_{pv} + P_{bat}) < P_{load}$, Grid energy will supply for loads with solar and battery.
	During discharge time, if $P_{pv} > AC_{RatePower}$, solar energy will supply $AC_{RatePower}$ for loads and Grid, and the extra solar energy will charge the battery instead of battery discharge.
When Grid, Battery is available (without PV)	
	During charge time, Grid will charge battery and supply power to the loads at the same time no matter PVchargeOnly is On or Off.
	During discharge time, if $P_{bat} > P_{load}$, battery discharge energy will supply for loads and extra battery discharge energy will feed in Grid.
	During discharge time, if $P_{bat} < P_{load}$, Grid will supply energy with battery together for loads.

7.9 Inverter Used Under Self-consumption Mode

When the system time of the inverter is not within the forced charging and discharging time set by "peakloadshifting", or the forced charge/discharge time of "peakloadshifting" is not enabled, the hybrid inverter automatically operates in self-consumption mode. The hybrid inverter detects the power of CT1/Meter1, when the PV is connected and the PV power is greater than the load power, the excess PV power will be output to the grid through CT1/Meter1.

At this time, the hybrid inverter automatically uses this excess PV power to charge the battery and reduce the backflow power to the grid. If there is no PV or the PV power is lower than the load power, the load will take power from the grid through CT1/Meter1. At this time, the hybrid inverter automatically controls the battery discharge to provide energy to the load and reduce the power taken from the grid.

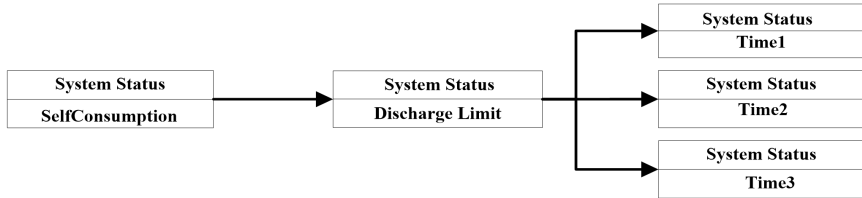

When the hybrid inverter is in "self-consumption" mode, if the user does not want to discharge the battery for a certain period of time, for example, If the price of utility power is relatively low during a certain period of time, it is more economic to use utility power than battery power. Users can access the "Discharge Limit" screen in "SelfConsumption" by pressing the "↑" or "↓" and "Enter" buttons, set and enable the limit battery discharge time. During this set time period, the battery is not discharged and the load is powered directly from the utility. The "self-consumption" mode also support three settable time periods to limit battery discharge.

Since self-consumption and peakloadshifting use the same SOC setting item. Therefore, you can set the charging and discharging SOC in self-consumption mode in the charging and discharging SOC option of peakloadshifting. Power rate is the same setting step.

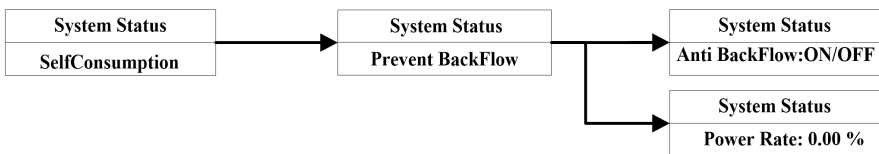

The hybrid inverter has an anti-backflow/0-export function. Users can use the "↑" or "↓" and "Enter" buttons to enter the "Prevent BackFlow" screen in "SelfConsumption" to set and enable the backflow prevention function. When the system has excess power to feed into the grid, the hybrid inverter limits the power output to the utility to the anti-backflow setting power (rated inverter power * backflow power percentage "Power Rate") via CT1/Meter1. When Anti BackFlow is set to ON, the anti-backflow function is on and inverter CANNOT feedback to grid; if set to OFF then the inverter CAN feedback to grid. The Power Rate option is only available when Anti BackFlow is set to ON. When set to 0%, 0 power is allowed to feed back to the grid;

when set to 50%, 50% of the inverter's rated power is allowed to feed to the grid. For example, if the 6KW inverter is set to 50%, it can feed up to 3KW to the grid.

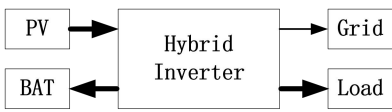
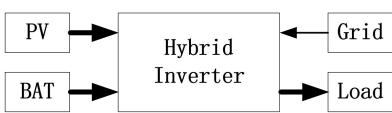
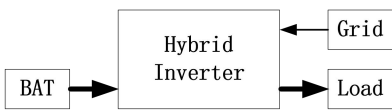
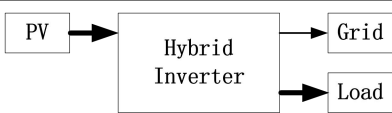
When PV, Grid, Battery is available	
	<p>When $P_{pv} > P_{load}$, extra solar energy is going to feed in Grid, battery will charge to reduce feed in Grid power. If $P_{pv} > (P_{bat} + P_{load})$, extra solar energy still feed in Grid, if Anti BackFlow is On, feed in Grid power will be limited at setting power rate.</p>
	<p>When $P_{load} > P_{pv}$, the loads is going to use Grid power, battery will discharge to reduce Grid consume power. If $P_{load} > (P_{bat} + P_{pv})$, Grid will supply for loads with solar and battery. But during discharge limit time, the battery can only charge and no discharge.</p>
When Grid is available, without PV or Battery	
	<p>When $P_{load} > 0$, the loads is going to use Grid power, battery will discharge to reduce Grid consume power. If $P_{load} > P_{bat}$, Grid will supply for loads with battery. During discharge limit time, the battery can only charge, loads use energy all from Grid.</p>
	<p>When $P_{pv} < P_{load}$, Grid will supply for loads with solar. When $P_{pv} > P_{load}$, extra solar energy will feed in Grid, if Anti BackFlow is On, feed in Grid power will be limited at setting power rate.</p>

7.10 Restore Default Factory Settings



When user need to restore the system to factory settings, user can use the "↑" or "↓" and "Enter" buttons to enter the "System Config" interface and select the "Development" option. When enter to "Development" screen, user need to long press "Enter" for 5 seconds to enter the password verification screen.

8 Maintenance and Cleaning

8.1 Maintain Periodically

1. Checking Heat Dissipation

If the inverter regularly reduces its output power due to high temperature, please improve the heat dissipation condition. Maybe you need to clean the heat sink.

2. Cleaning the Inverter

If the inverter is dirty, turn-off the AC breaker and DC switch ,waiting the inverter shut down ,then clean the enclosure lid, the display, and the LEDs using only a wet cloth. Do not use any cleaning agents (e.g. solvents or abrasives)

3. Checking the DC switch

Check for externally visible damage and discoloration of the DC switch and the cables at regular intervals.If there is any visible damage to the DC switch, or visible discoloration or damage to the cables, contact the installer.

8.2 Trouble shooting

Our quality control program assures that every inverter is manufactured to accurate specifications and is thoroughly tested before leaving our factory. If you have difficulty in the operation of your inverter, please read through the following information to correct the problem.

Alarm ID	Alarm Name	Suggestion
W5	Meter COM Err	1. Check whether the meter matches the inverter protocol. 2.Check the wire connection between meter and inverter is good or not.
W8	BMS COM Err	1.Check the lithium Battery is open or not. 2.Check the connection of lithium Battery and inverter is good or not.
W11	BAT NTC Open	1.Check the temperature of lead-acid battery is installed or not. 2.Check the temperature of lead-acid battery is connected well or not.
W14	Bat Temp Out	Check the environment temperature of battery is in the range of specification or not.
W15	Over Load!	Please reduce the load of UPS output.
W17	Bat Need Chg	1. Set the battery stop discharge SOC to a higher value 2. Charge the battery properly

W18	BMS Warn	Check the warning information from lithium battery user manual.
W26	AC Volt Out	1.Check the AC voltage is in the range of standard voltage in specification. 2.Check the grid connection is good or not.
W27	DCI High	Restart inverter. Please contact the manufacturer if restart can't solve the problem.
W28	No AC Input	1.Please confirm grid is lost or not. 2.Check the grid connection is good or not. 3.Check the switches on the cable are on or not.
W29	AC Freq Out	Check the frequency is in the range of specification or not. Restart inverter. Please contact the manufacturer if restart can't solve the problem.
W30	Bat Reversed	Check the positive and negative of battery is reversed or not.
W31	Battery Open	Check the battery connection is good or not. Check the switches between the battery and inverter are all on or not.
W32	BatVolt High	Check the voltage of battery is in the range of specification or not. Check the battery connection is right or not If battery is really higher than 60V. Please disconnect the connection of battery and check inverter.
W33	Bat Volt Low	Check the real voltage of battery. Check the wire of battery and inverter is good or not.
W34	EPS Volt Low	Check the load of Back-Up. If overload occurred, reduce load. Restart inverter again.

Alarm ID	Alarm Name	Suggestion
E0	N-PE Fault!	Check the L line and N line is reversed or not. Check the PE s connected well or not.
E1	PV Iso Low!	Check the connection of PV panels and inverter is good or not. Check the PE of inverter is good or not.

E2	Relay Fault!	Restart inverter.Please contact the manufacturer if restart can't solve the problem.
E3	BusVolt High!	Check the PV input voltage. Do not exceed the range of specification. Restart inverter.Please contact the manufacturer if restart can't solve the problem.
E5	Firmware Err!	Read DSP and COM firmware version from LCD. Check if the firmware is correct
E6	ARM RX Fault!	Restart inverter.Please contact the manufacturer if restart can't solve the problem.
E7	DSP RX Fault!	Restart inverter.Please contact the manufacturer if restart can't solve the problem.
E8	BackUp Short!	Check the load of BackUp. Check the output of UPS. Especial not connect to grid
E9	AuotTest Err!	Restart inverter.Please contact the manufacturer if restart can't solve the problem.
E10	Model Fault!	Checking Model Settings. Please contact the manufacturer if restart can't solve the problem.
E11	NTC Open!	Restart inverter.Please contact the manufacturer if restart can't solve the problem.
E13	BDC OTP!	Please check the temperature is in the range of specification or not.
E16	PV Volt High	Please check the voltage of PV input is in the range of specification or not.
E18	BST OTP!	Please check the temperature is in the range of specification or not.Please contact the manufacturer if restart can't solve the problem.
E19	INV OTP!	Please check the temperature is in the range of specification or not.Please contact the manufacturer if restart can't solve the problem.
E22	GFCI High!	Check the cable of inverter. Restart inverter.Please contact the manufacturer if restart can't solve the problem.

9 Decommissioning

9.1 Remove the Inverter

- ◆ Disconnect the inverter from DC Input and AC output.
- ◆ Wait for 5 minutes for de-energizing.
- ◆ Disconnect communication and optional connection wirings.
- ◆ Remove the inverter from the bracket.
- ◆ Remove the bracket if necessary.

9.2 Packaging

- ◆ Please pack the inverter with the original packaging.
- ◆ If the original package is no longer available, you can also use an equivalent carton that meets the following requirements.

9.3 Storage and Transportation

- ◆ Store the inverter in a dry environment where ambient temperature keep always between -20 °C - +60 °C. Take care of the inverter during the storage and transportation, keep less than 4 cartons in one stack.
- ◆ When the inverter or other related components need to be disposed. Have it carried out according to local waste handling regulations. Please be sure to deliver wasted inverters and packing materials to certain site, where can assist relevant department to dispose and recycle.

10 Technical Data

Model	JH-3K-ML	JH-3.6K-ML	JH-4K-ML	JH-5K-ML	JH-6K-ML
PV String Input data:					
Max. recommended PV power	7KW	7KW	9KW	9KW	9KW
Max. DC voltage	550V				
Nominal voltage	360V				
MPP Working voltage range	90V-550V				

Full load dc voltage range	300V-450V				
Start voltage/Minimum working voltage	100V/80V				
Number of independent MPP trackers / strings	2/1				
Max. input current of tracker A/ tracker B	15A/15A				
AC Output Data (Grid) :					
Rated AC output power	3KW	3.6KW	4KW	5KW	6KW
Max. AC apparent power	3.3KVA	4KVA	4.4KVA	5.5KVA	6.6KVA
Max AC Input power	6KW	7.2KW	8KW	10KW	12KW
AC output voltage range	230V \pm 20%				
Rated AC output frequency	50 /60 \pm 5 Hz				
Max AC output current	14A	17A	19A	24A	29A
Max AC input current	28A	32A	38A	48A	58A
Power factor	\pm 0.8				
Maximum total harmonic distortion	<3%				
Gird standard	L+N+PE				
AC output Data (Back-up):					
Peak output apparent power	4KVA, 10S	4.6KVA, 10S	5KVA, 10S	6KVA, 10S	7KVA, 10S
Rated AC output power	3KVA	3.6KVA	4KVA	5KVA	6KVA
Rated AC output voltage	230V \pm 20%				
Rated AC output frequency	50/60 \pm 0.2%				
THDV@Rated Linear load	<3%				

Transfer Time	<10ms				
Battery data:					
Battery Type	Lithium /Lead-acid				
Nominal voltage	48V				
Battery voltage range	42V-59V				
Max charging current	80A	80A	100A	100A	100A
Max discharging current	80A	80A	100A	100A	100A
Capacity of battery	25-2000AH				
Charging Strategy for Li-Ion Battery	Self-adaption to BMS				
Charging Strategy for Lead-acid Battery	3 Stages				
Efficiency:					
MPPT efficiency	99.9%	99.9%	99.9%	99.9%	99.9%
Max. efficiency	98.0%	98.0%	98.0%	98.0%	98.0%
Euro weighted efficiency	97.5%	97.5%	97.5%	97.5%	97.5%
Max. Charge and discharging efficiency	94.0%	94.0%	94.0%	94.0%	94.0%
General Data:					
Dimensions (W / H / D)	375*363*250				
Weight	20kg				
Operating temperature range	-25 °C ... +60 °C				
Noise emission (typical)	≤25dB				
Cooling concept	Natural				
Environmental Protection	IP65				

Rating	
Altitude	3000m
Installation style	Wall mounted
Self-Consumption	<3W
Inverter Topology	Transformerless
Display	LCD and App
Interfaces	WiFi/GPRS
Warranty	5 years

11 Appendix

Approved battery brand from Johnray.

Brand	RS485 or CAN
JOHNRAY	CAN
PYLON	CAN
	RS485
PYLON 3.0	RS485
DYNESS	CAN
ATL	CAN
	RS485
GenixGreen	RS485
	CAN
VTC	RS485
ZETARA	CAN
	RS485
EVE	RS485

12 Manufacturer’s Warranty

Please refer to the warranty card.

13 Contact

If you have technical problems concerning our products, contact your installer or manufacturer. During inquiring, please provide below information:

1. Inverter type
2. Modules information
3. Communication method
4. Serial number of Inverters
5. Error code of Inverters
6. Display of inverter LCD



Suzhou Johnray Solar Energy Co., Ltd

No. 60, Chuangye Street, High-tech Zone, 215011 Suzhou, Jiangsu, China

+86 (0) 512 65100899

info@johnrayenergy.com

www.johnrayenergy.com